

Flexible solutions for pellet production and use

first agri-pellets

- first Hungarian agri-pellets*
- experiments started in 2002*
- capacity ca. 250 kg/h*
- energy grass and straw*
- 8-12 mm diameter*

characteristics of agri-pellets

- *energy level: 15-24 MJ/kg*
- *ash content: 6-8%*
- *length diameter ratio: $L = 0,5 \dots 10xD$*
- *bulk density: 450-650 kg/m³*
- *muldering during storage and transport: 5-10%*
- *low cost, high volume, locally available*
- *corrosive content*

Pellets for Europe

ALTENER 2002-012-137-160

EUBIA

*Analysis of the technical obstacles related to
the production and utilisation of fuel pellets
made from agricultural residues*

Summary of conclusions

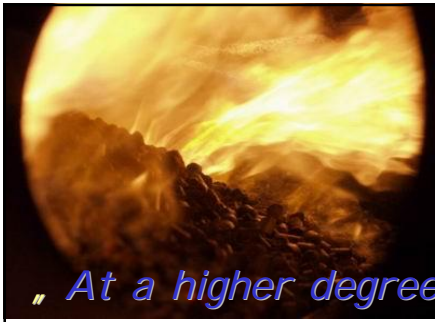

Pellets for Bioenergy: addressing the challenges

5

„ At a higher degree than for wood pellets, the main technical challenges regarding agri-pellets are the production of a high quality fuel, and technological improvement for small-scale combustion devices. Assuming that economic aspects concerning the agri-pellets energy option are favourable, the agri-pellet market for small-scale use will develop only if equipment manufacturers are encouraged to develop novel, safe and affordable combustion solutions. ”

10 May 2007 Utrecht, The Netherlands

Pellets for Bioenergy: addressing the challenges

6

what to do with the agri-pellets?

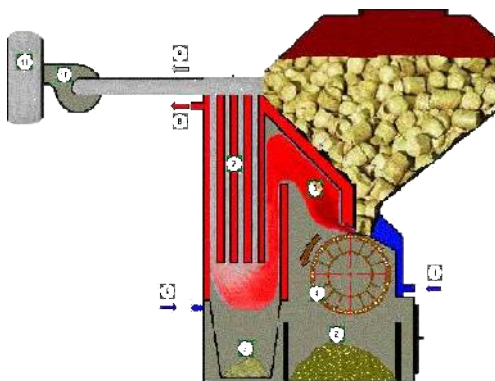

- *mutual development with boiler factory*
- *25 year old design*
- *automatic coal boiler*
- *modified for pellets*
- *coal burning remains*
- *2 years field testing*

10 May 2007 Utrecht, The Netherlands

Pellets for Bioenergy: addressing the challenges

7

boiler for pellets? pellets for boiler?

great flexibility offered by CARBOROBOT:

- *diameter: 5-25mm*
- *ash content: up to 20%*
- *heat value: 13..33 MJ/kg*
- *density: 250..650 kg/m³*
- *30-300 kW or more*



Utrecht, The Netherlands Pellets for Bioenergy: addressing the challenges

8

building agri-pellet production

- *development of experimental pellet factory with T&T Technik Ltd.*
- *15 years of expertise in lucern pelleting*
- *modified feed ring dye pellet press (100kW)*
- *background machine factory on place*
- *installed in existing building*
- *successful pellet production since half year*



10 May 2007 Utrecht, The Netherlands

Pellets for Bioenergy: addressing the challenges

9



main characteristics of factory

- *250kW build in power (50kW bale shredder)*
- *1-2 ton per hour capacity (depend on raw material and pellet size)*
- *two biomass inputs: bale, chip grate*
- *without dryer up to 20% moisture content*
- *bulk, big-bag, small bag*



10 May 2007 Utrecht, The Netherlands

Pellets for Bioenergy: addressing the challenges

10



various bio"mass" types and forms

- *wheat straw, rape straw, energy grass, corn, whole crops, wood chips, sawdust, wood shavings with bark, oil press cake, tailings, etc.*
- *energy level can be set by adding oil press cake*
- *complete utilization of rape or sunflower: straw mixed with oil press cake before pelleting*

special features

- *flexible raw materials, no additives necessary*
- *no need of dryer for carefully handled and stored agricultural raw material*
- *process steam from scrap material*
- *continuous flow – small buffer: 1-2 bale*
- *low cost ca. 400 000 Euro*
- *low automation level (education level, biomass)*
- *easy maintenance*

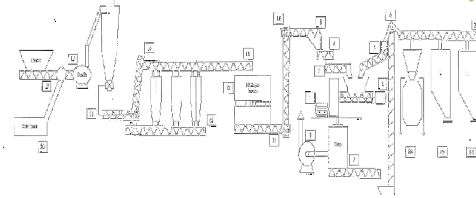

Small scale flexible agri-energy system

smallest - smartest

- *the smallest "pellet" press: 10kg/hour, 70t/a*
- *energy consumption per hour: ca. 1kW*
- *continuous operation over 7000 hour per year*
- *totally automatic operation, maintenance free*
- *20 year old technology*
- *low cost: ca. 2000 Euro*

autonomous energy system for farmers



*cold oil press:
pure plant oil*

*CHP - cogeneration:
electricity and
domestic hot water*

*press cake:
animal feed
heat source*

*self energy
cultivated on 2 Ha*

press cake = press pellets

- *directly can be used in CARBOROBOT boiler*
- *5-6 mm diameter*
- *can be stored for long time (over a year)*
- *high energy density: 21-24 Mj/kg*
- *low price: 140 Euro/ton, 0,21 Euro/kWh*
- *can be mixed with other agri-pellets to raise the average energy content*

Thank You!

Mr. Ákos Ferencz
cropell@mobilposta.hu
www.cropell.hu